

RETRO-FIT FILTER COMBINATION UNITS



Made of heat-moulded ABS, and high quality acrylic finish and advanced design. Specially designed to install in all types of private pools, whether concrete or prefabricated. The compact unit saves the traditional pipework assembly.

The Combo units consist of two separate parts:

- 1) The first part is designed for installation inside the pool and contains the skimmer, return and suction inlets, an underwater light is optional.
- 2) The second part incorporates the pump, filtration equipment, control box and depending on model type, chlorinator, electric heater and transformer for the light. It also includes water discharge connection for backwashing and drainage plug.

The two units can be installed as one compact unit (being adaptable to any type of pool with a wall thickness of 180 to 300 mm) or as a split unit installing the filtration part in a convenient spot not more than 3.5 m away.



Combo I

With 3/4 HP pump with 11 m³/h flow at 10 m.h.w., 3 cartridge filters of 5 m³/h flow rate each. Total filtration surface 6.9 m². Control box included.

| Code | Standard Packaging | Standard Weight Kg | Standard Volume m ³ |
|-------|--------------------|--------------------|--------------------------------|
| 18546 | 1 | 92 | 1.241 |



Combo II

With Terra 50 cartridge filter with maximum flow 10 m³/h, Sena pump 3/4 HP, 100 W light and programmable control box. An electric heater and chlorinator can also be incorporated. One single filter replaces the three used in Combo I. Improved return of water to pool. This Combo II can also be installed as one compact unit or can be installed as 2 separated parts.

| Code | Standard Packaging | Standard Weight Kg | Standard Volume m ³ |
|-------|--------------------|--------------------|--------------------------------|
| 27413 | 1 | 79 | 1.41 |

White cartridge filter, 10 m³/h flow

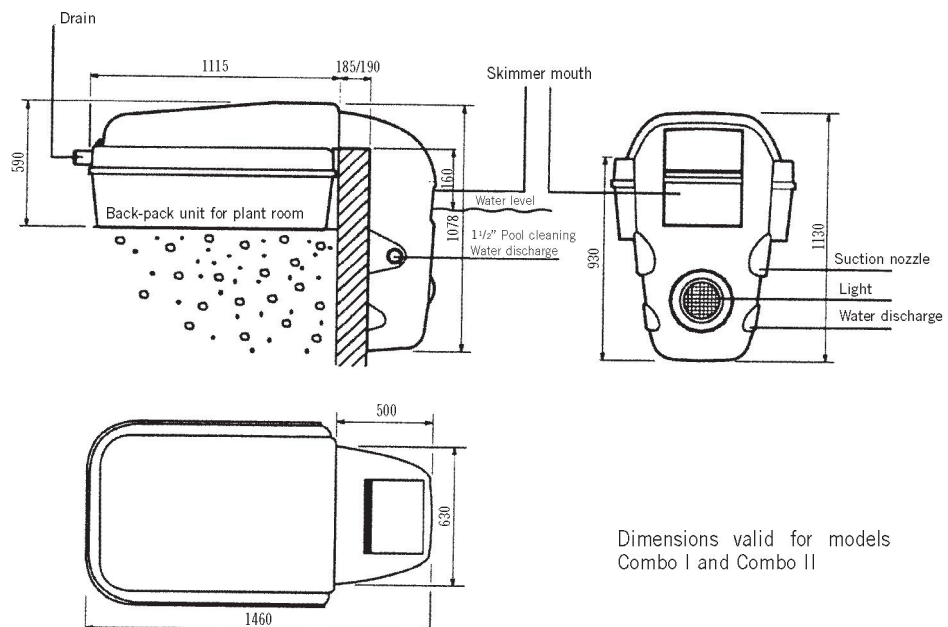

Dimensions valid for models
Combo I and Combo II